

Technical Data Sheet – Magnetic strip for cast-in channel

Product Description

The Magnetic strip for cast-in channels is a magnetic fastener for an easy insertion in the cast-in channel. After insertion, it is directly applicable. No bonding, no adhesive residues, easy positioning.

Product Features

- ∴ No bonding of cast-in channel to tilting table
→ no adhesive residues
- ∴ Magnet is reusable
- ∴ Easier positioning in comparison to use of adhesive
- ∴ Filling does not have to be removed from the channel

Areas of Application

- ∴ Shuttering magnet for pallet circulation systems as well as tilting tables
- ∴ Formwork for walls, columns etc.



The information in this data sheet was provided with care based on our experience and the respective known state of science and technology but is non-binding. They are to be adapted to the respective building object, intended use and the special local stresses. Provided that this is the case, we ask you to understand that we limit our liability for the information given in this data sheet and accept no liability in the event of intent, gross negligence or infringement of the instructions. In any case, the recognised rules of technology must be observed.

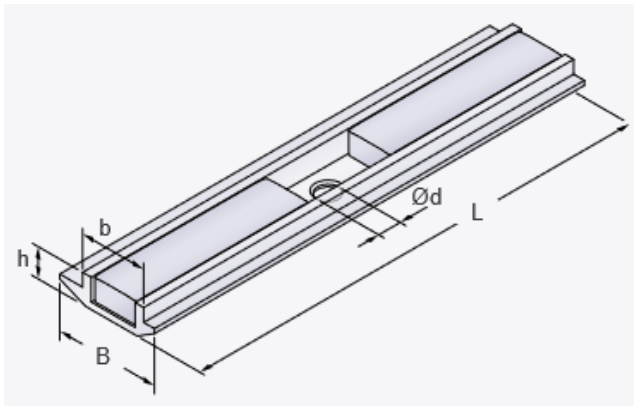

Edition 11/22 - This data sheet has been technically revised. Previous editions are invalid. If a new edition has been technically revised, this edition loses its validity. Please check whether you are in possession of the current edition.

Technical Data

Dimensions

Article number	Bezeichnung	adhesive force	L [mm]	B [mm]	b [mm]	h [mm]	Ød [mm]
8009144	Magnetic strip for cast-in channel 28/15	ca. 250 N	100	15,5	9,2	5,0	5,0
8009145	Magnetic strip for cast-in channel 38/17	ca. 300 N	100	22,0	14,2	6,5	5,0
8009146	Magnetic strip for cast-in channel 40/25	ca. 300 N	100	23,5	14,2	8,0	5,0